

2910 VALVE

SPARE PARTS

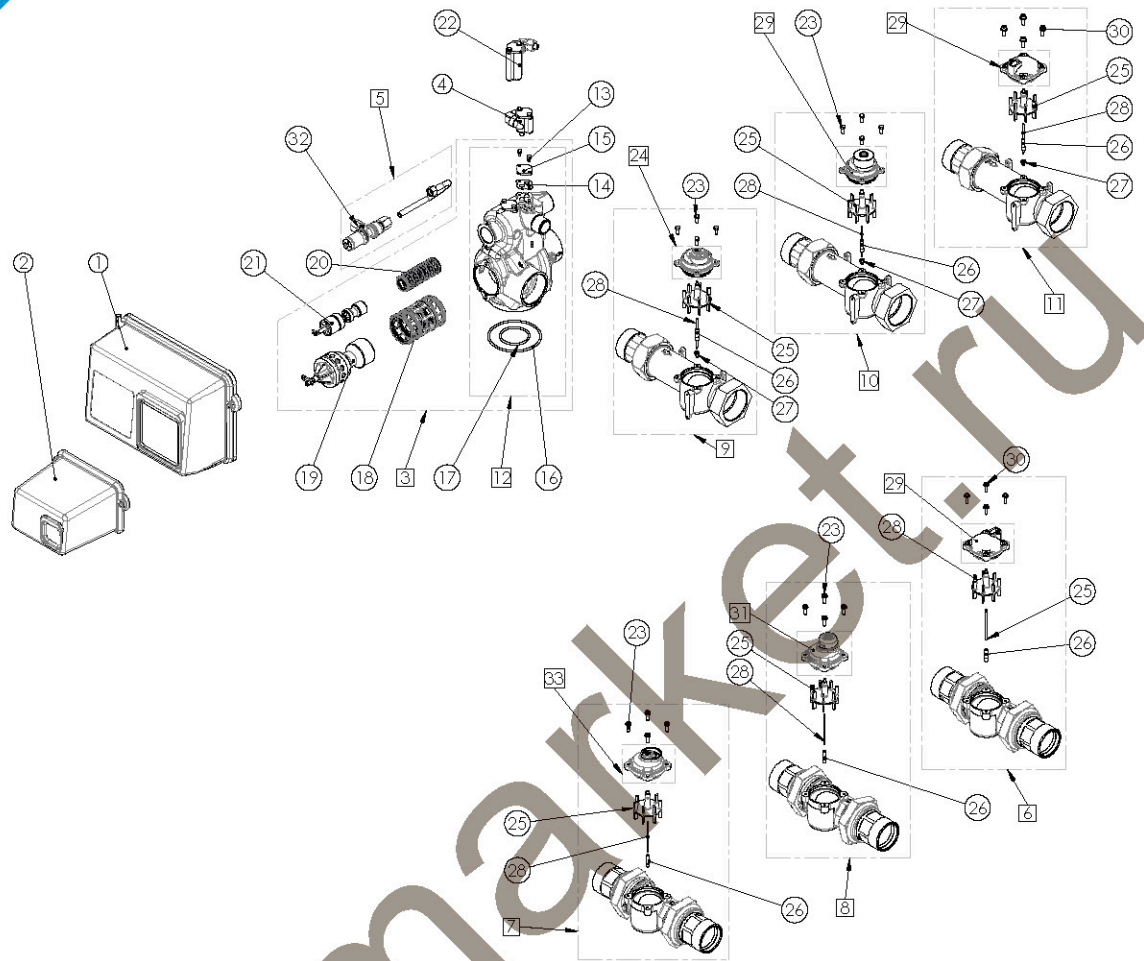

2910 spare parts

Item	Reference	Description	Packing qty
1	VCPHINDUS1	Power head 2510/2750/2850/2910 - See VC sub-assemblies section	
2	PH2910-001	PH 2910 adapt 24V/50Hz 1 msw	1
	PH2910-002	PH 2900/2910 adapt NXT 24V/50Hz	1
	PH2910-006	Power head adapter 2910 230V no timer	1
3	BU28515-01	VB assy 2910 DF	1
	BU28515-02	VB assy 2910 DF/NBP	1
	BU28515-03	VB assy 2910 DF HW	1
	BU28515-04	VB assy 2910 DF/NBP HW	1
	BU28515-05	VB assy 2910 UF	1
	BU28515-06	VB assy 2910 UF/NBP	1
4	24199-0	Inj assy 1600 2750/2850/2900/2910	1
	24199-00	Inj assy 1600 2750/2850/2900/2910	1
	24199-000	Inj assy 1600 2750/2850/2900/2910	1
	24199-1	Inj assy 1600 2750/2850/2900/2910	1
	24199-2	Inj assy 1600 2750/2850/2900/2910	1
	24199-3	Inj assy 1600 2750/2850/2900/2910	1
	26840-0	Inj assy 1600 2750/2910 UF # 0	1
	26840-1	Inj assy 1600 2750/2910 UF # 1	1
	26840-2	Inj assy 1600 2750/2910 UF # 2	1
	26840-3	Inj assy 1600 2750/2910 UF # 3	1
	24555-0	Inj assy 1600 HW	1
	24555-1	Inj assy 1600 HW	1
	24555-2	Inj assy 1600 HW	1

2910 VALVE

SPARE PARTS

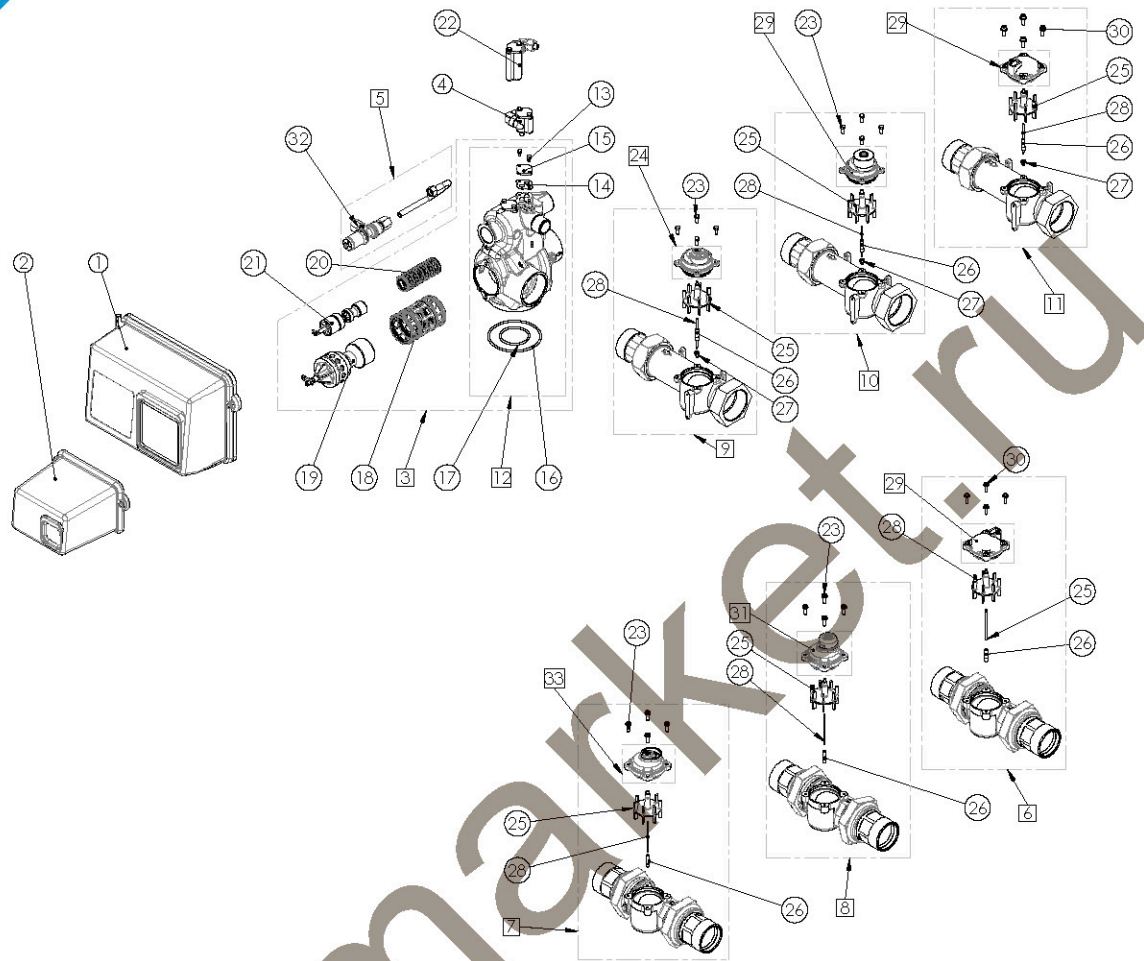

2910 spare parts

Item	Reference	Description	Packing qty
	24555-3	Inj assy 1600 HW	1
5	BU28797-0.25	BV 1650 assy 2750NBP/2850/2910 0.25 gpm	1
	BU28797-0.50	BV 1650 assy 2750NBP/2850/2910 0.50 gpm	1
	BU28797-1	BV 1650 assy 2750NBP/2850/2910 1 gpm	1
	26909-0.50	BV 1600 assy 2750NBP/2850 0.50 gpm	1
	26909-1	BV 1600 assy 2750NBP/2850 1 gpm	1
	BU28610-1.2	BV 1710 2750 NBP/2850 WBP/2910 1.2 gpm	1
	BU28610-2	BV 1710 2750 NBP/2850 WBP/2910 2 gpm	1
	BU28610-4	BV 1710 2750 NBP/2850 WBP/2910 4 gpm	1
	BU28610-7	BV 1710 2750 NBP/2850 WBP/2910 7 gpm	1
	BU28614-1.2	BV 1710 2910 UF 1.2 gpm	1
	BU28614-2	BV 1710 2910 UF 2 gpm	1
	BU28614-4	BV 1710 2910 UF 4 gpm	1
	BU28614-7	BV 1710 2910 UF 7 gpm	1
	24994-1	BV 1600 assy 2750 WBP/2910 HW 1 gpm	1
	24994-0.25	BV 1600 assy 2750 WBP/2910 HW 0.25 gpm	1
	24994-0.50	BV 1600 assy 2750 WBP/2910 HW 0.50 gpm	1
	BU28807-0.25	BV 1650 assy 2910 UF 0.25 gpm	1
	BU28807-0.50	BV 1650 assy 2910 UF 0.50 gpm	1
	BU28807-1	BV 1650 assy 2910 UF 1 gpm	1
	26991-1.2	BV 1700 assy 2750 NBP/2850 WBP/ 2910 1.2 gpm	1
	26991-2	BV 1700 assy 2750 NBP/2850 WBP/ 2910 2 gpm	1
	26991-4	BV 1700 assy 2750 NBP/2850 WBP/ 2910 4 gpm	1

2910 VALVE

SPARE PARTS

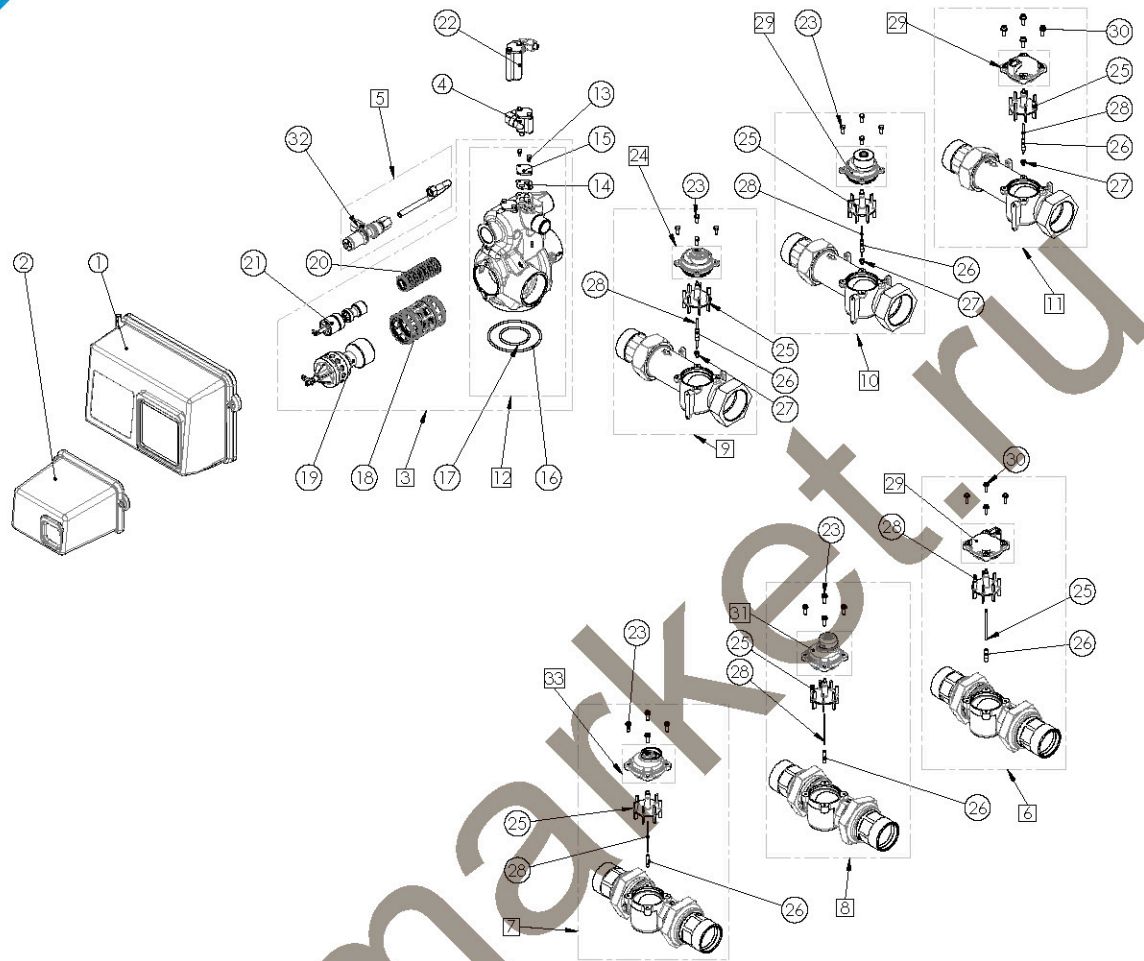

2910 spare parts

Item	Reference	Description	Packing qty
6	60625-10	Meter assy 2" elec plastic	1
7	60620-10	Meter assy 2" 75 m ³ plastic	1
8	60621-10	Meter assy 2" 375 m ³ plastic	1
9	24148	Meter assy 2" 75 m ³	1
10	24149	Meter assy 2" 375 m ³	1
11	18393	Meter assy 2" elec	1
12	28411	VB 2910 w/ O-ring	1
13	24874SP	Screw THM 5 x 8 -(50 pc)	1
14	19925SP	Gasket -(10 pc)	1
15	11893SP	Inj Flat Cover -(10 pc)	1
16	13575-01SP	O-ring 560 CD Top of Tank -(5 pc)	1
17	13577-01SP	O-ring 560 CD Distrib Tube -(10 pc)	1
18	24205	S&S kit 2900/2910 lower	1
	26107	S&S kit 2900/2910 lower HW	1
19	BU28412	Piston assy lower 2900/2910	1
	BU28413	Piston assy lower 2900/2910 NBP	1
20	28415	S&S kit upper	1
	BU28414	S&S kit 2750/2900/2910 upper HW	1
21	28417	Piston assy 2910 upper UF	1
	28416	Piston assy 2910 upper	1
22	24173-3	Inj assy 1700/1710	1
	24173-4	Inj assy 1700/1710	1
	24173-5	Inj assy 1700/1710	1

2910 VALVE

SPARE PARTS

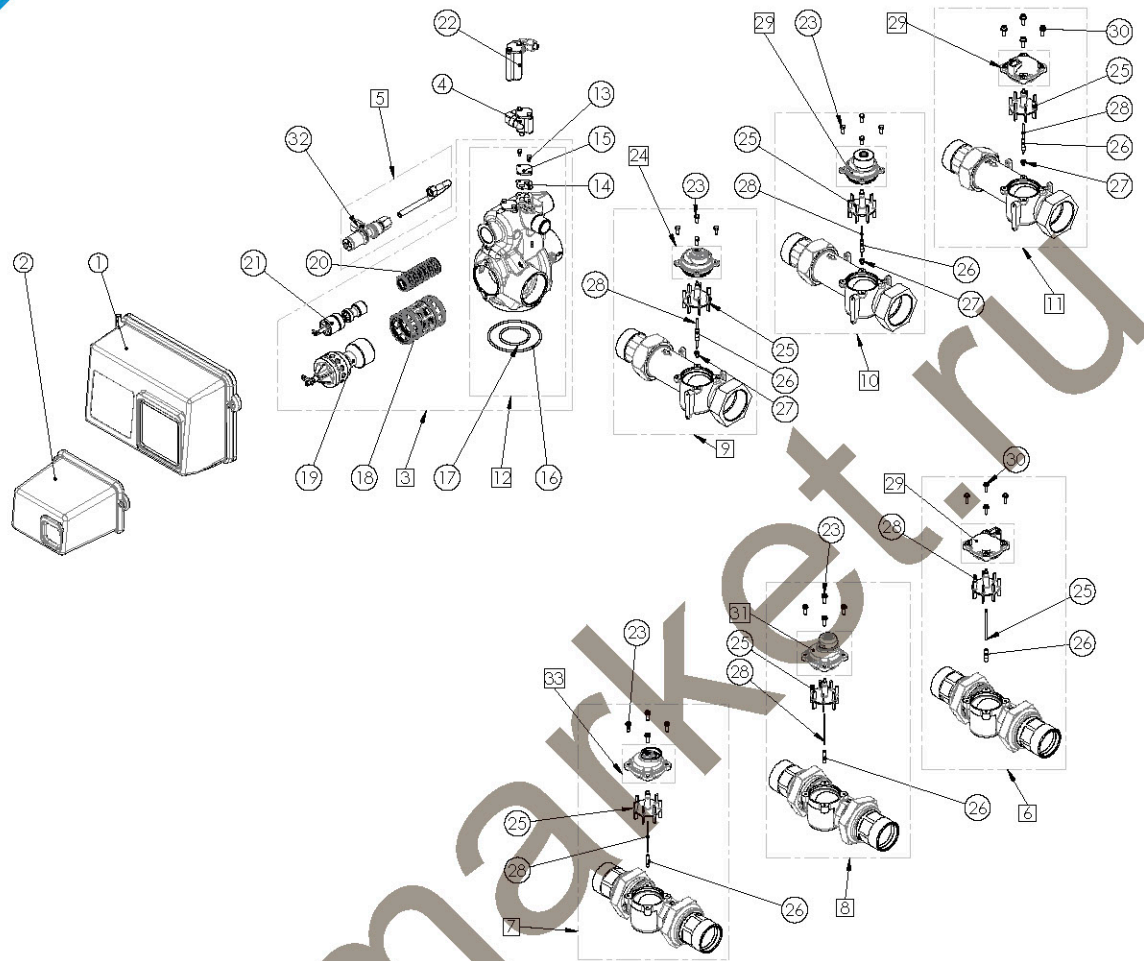

2910 spare parts

Item	Reference	Description	Packing qty
	26841-3	Injector assy 1700/1710 UF #3c	1
	26841-4	Injector assy 1700/1710 UF #4c	1
	26841-5	Injector assy 1700/1710 UF #5c	1
	26841-6	Injector assy 1700/1710 UF #6c	1
	28422-6	Inj assy 1710 2910 # 6C	1
	28422-7	Inj assy 1710 2910 # 7C	1
23	11737SP	Screw TH M5x12 - (50 pc)	1
24	15218	Cover meter assy brass	1
25	BR15374	Impeller 2"	1
26	BR15432	Impeller shaft for impeller 15374-01	1
27	15381	Impeller plug 2" meter	1
28	15532	Impeller shaft bearing	1
29	18330	Meter cover assy elec	1
30	12473SP	Screw Hex Washer 10-24x $\frac{5}{8}$ 18-8SS - (50 pc)	1
31	15237	Meter cover assy brass extended	1
32	18092-0.25	Kit BV 1600 & BLFC assy indus	1
	18092-0.50	Kit BV 1600 & BLFC assy indus	1
	18092-1	Kit BV 1600 & BLFC assy indus	1
	26677-0.25	Kit BV 1650 assy 0.25 gpm	1
	26677-0.50	Kit BV 1650 assy 0.50 gpm	1
	26677-1	Kit BV 1650 assy 1 gpm	1
	24181-1.2	Kit BV 1700 assy	1
	24181-2	Kit BV 1700 assy	1

2910 VALVE

SPARE PARTS

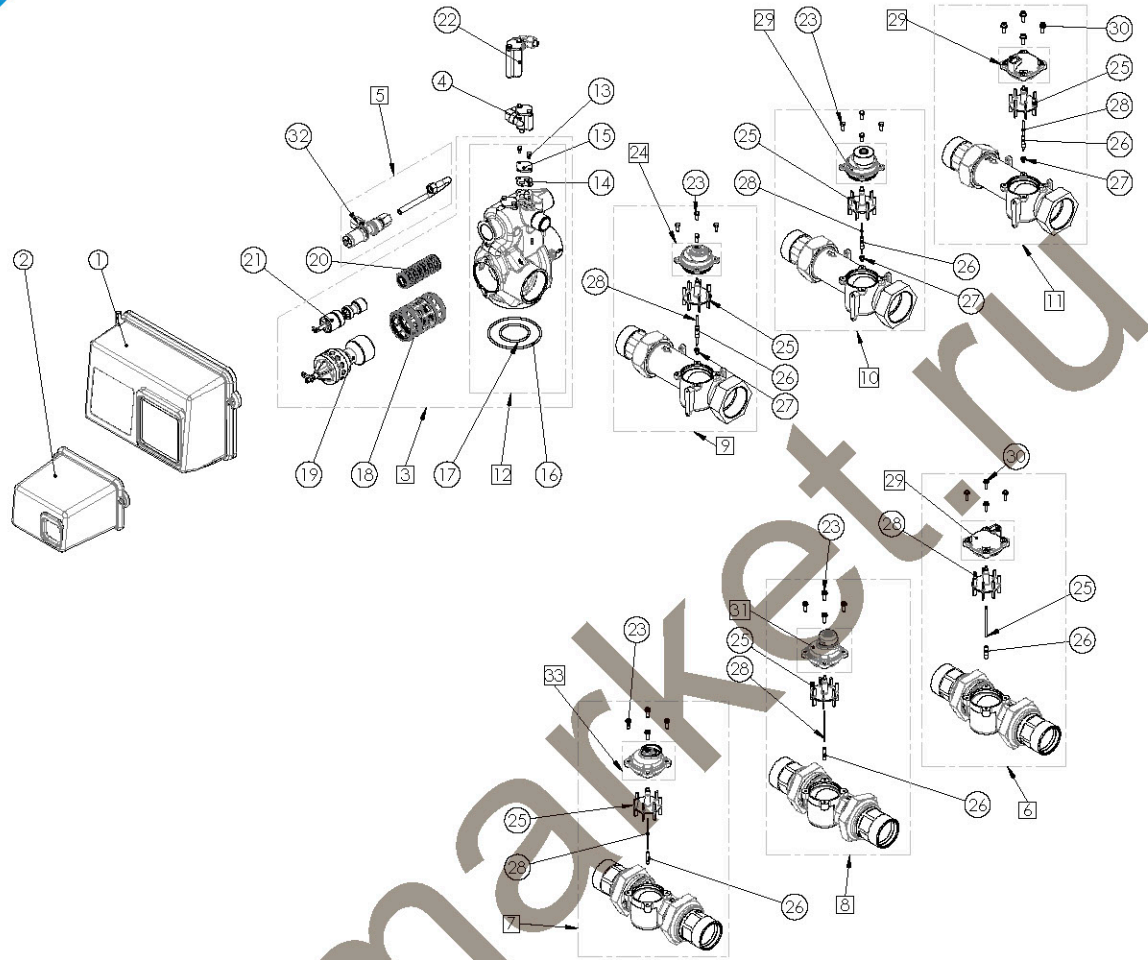

2910 spare parts

Item	Reference	Description	Packing qty
	24181-4	Kit BV 1700 assy	1
	24181-7	Kit BV 1700 assy	1
	28423-1.2	BV 1710 1.2 gpm except 9500	1
	28423-2	BV 1710 2 gpm except 9500	1
	28423-4	BV 1710 4 gpm except 9500	1
	28423-7	BV 1710 7 gpm except 9500	1
33	BR14038	Cover meter assy plastic	1

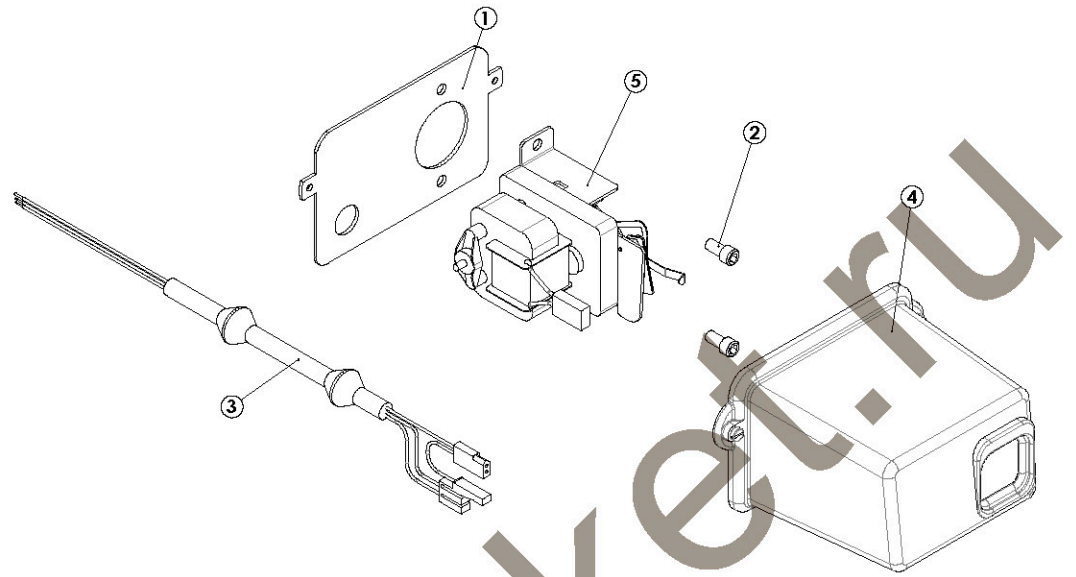

Power head 2910 adapter

Item	Reference	Description	Packing qty
1	18709-50	Back plate 2900/2910 lower	1
2	21361SP	Screw TCHCM 8x16 - (50 pc)	1
3	BR42446	Harness lower drive (ex 40405)	1
	40943	Harness 3200NT lower	1
4	26218-01	Cover assy 2900/2910 lower grey	1
5	18357-01	Motor assy 2910 adapt 24V	1

2910 VALVE

SPARE PARTS

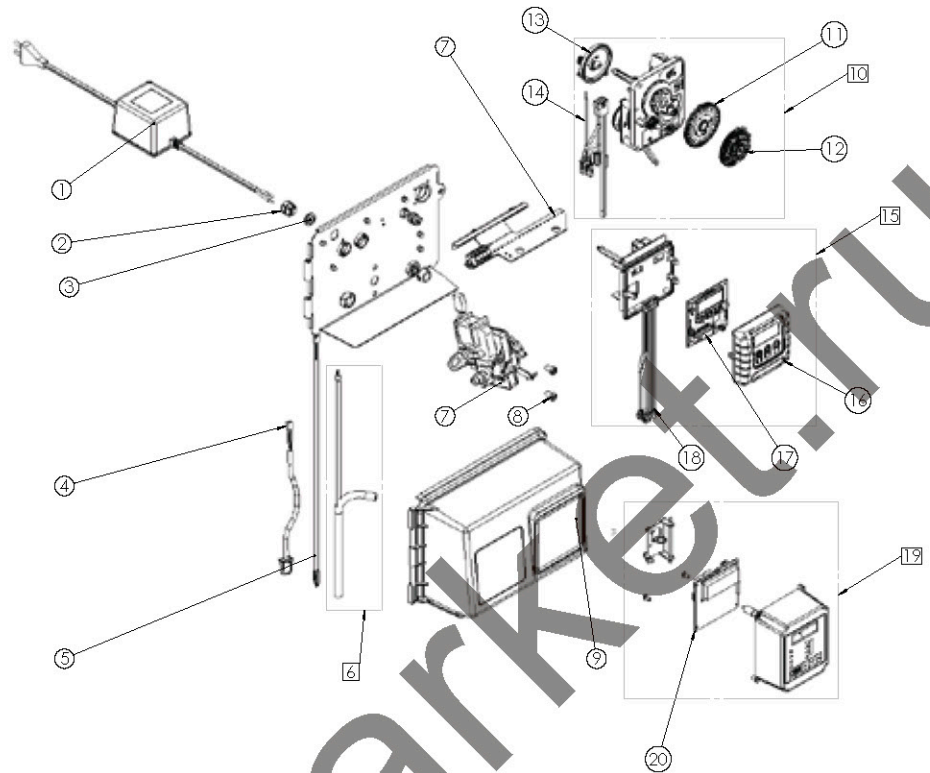

VCPHINDUS1

Item	Reference	Description	Packing qty
1	26260	Transfo 60VA	1
1	11545	Power cord european black	1
2	13547SP	Strain Relief 24V - (50 pc)	1
3	28704SP	Plug - (10 pc)	1
4	19121-01	Meter cable SE/SXT 0,450 m	1
5	BR19791-01	Turbine meter cable elec 0,450 m	1
6	27895	Guide cable & cable assy 2510 3/4" 8 m ³	1
	28380	Guide cable & cable assy 2510 3/4" 40 m ³	1
	25348	Guide cable & cable assy 2750 3/4"	1
	25349	Guide cable & cable assy 2750 1"	1
	25350	Guide cable & cable assy 2850 1"	1
	27105	Guide cable & cable assy 2850 1 1/2"	1
	25351	Guide cable & cable assy	1
7	27204-01	Drive motor assy 2510/2750/2850 DF 24V	1
	27204-31	Drive motor assy 2910 DF 24V	1
	27927-31	Drive motor assy 24V 50/50Hz 2910 UF	1
8	10231SP	Screw Hex Head Indus - (50 pc)	1
9	26217-01	Cover assy grey - clear window	1
10	VCTIMER	Timer mechanical industrial - See VC sub-assemblies section	
11	13009-21SP	24 hour gear - (10 pc)	1
12	14860	Skipper wheel assy 7 days	5
	24100	Skipper wheel assy 12 days	5
	24119	Pgm wheel assy 8 m ³	1
	24120	Pgm wheel assy 40 m ³	1
	24535	Pgm wheel assy 375 m ³ 2900/2910/3150	1

2910 VALVE SPARE PARTS

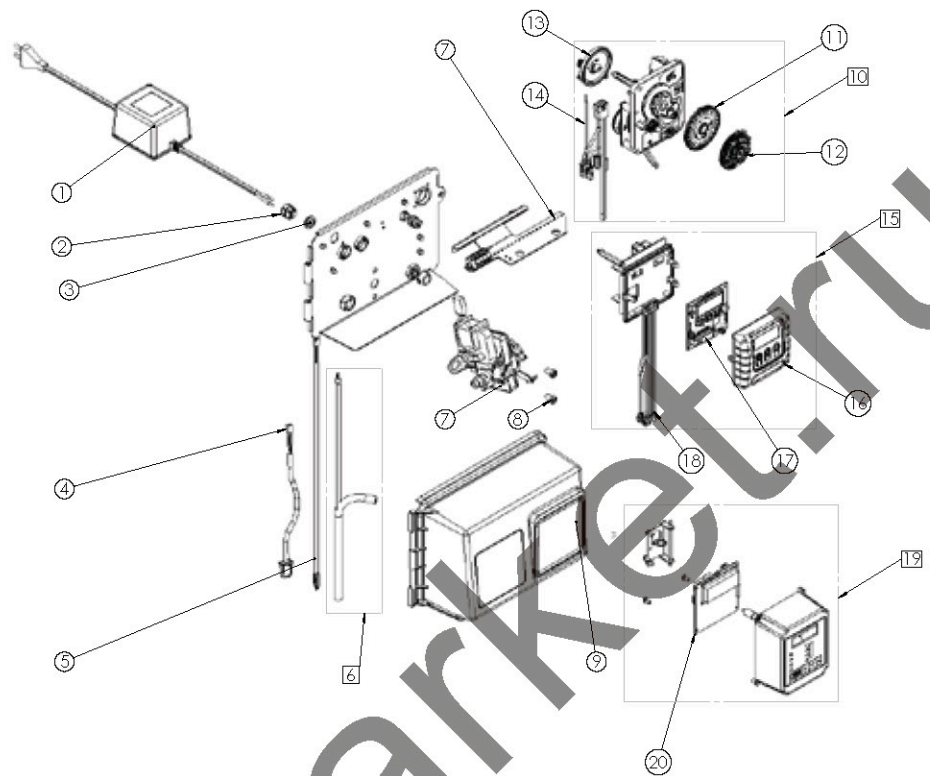

VCPHINDUS1

Item	Reference	Description	Packing qty
	24536	Pgm wheel assy 75 m ³ 2900/2910/3150	1
	24537	Pgm wheel assy 100 m ³	1
	24538	Pgm wheel assy 20 m ³	1
	BU25028	Program wheel assy 200 m ³ 2850/2900/2910	1
13	24201	Pgm wheel assy 160 min	5
14	15203	Harness timer 9000/ 9500	1
15	BU28712-01	Timer assy SXT 2510/2750/2850/2910	1
16	BU28714	Cover front panel & label SXT	1
17	BR43346-E0	Circuit board SXT programmed eco	1
18	BU28600	Wire harness power SXT	1
19	BU28713	Timer assy NXT	1
	27724-01	Timer et induc DF	1
	27724-02	Timer et induc UF	1
20	BU28529	Circuit board ET	1
	BR61702-03	Circuit board NXT	1
	28008	Harness pulse timer 3230 (not shown)	1
	40400	Harness motor ex 11667 (not shown)	1
	40422SP	Wire Nut Tan - (50 pc)	1
	40941	Harness upper drive NXT (not shown)	1